



GENERAL DESCRIPTION

FAN

Space saving integration of motor and impeller
 Rolled steel casing
 Fan guard with integral motor mounting to DIN and UNE standards
 Impeller in Polyamide 6 with fibreglass reinforcement
 Dynamically balanced to ISO 1940
 Zinc phosphate surface treated steel
 Epoxy resin anti-corrosive finish, kiln dried at 200°C

MOTOR

Squirrel-cage induction motor
 Three-phase dual voltage connection 230/400V 50Hz
 Single Phase 230V 50Hz
 IP65 dust and hosed water protection
 Class F winding insulation with Class B temperature rise
 Over-heat protection by self-resetting thermo-contact
 Permitted air-stream temperatures:
 2 pole (2800/min) motors -25°C up to +45°C
 4 pole (1400/min) & 6 pole (930/min) motors -25°C up to +60°C

Model	Airflow rate <i>m³/h</i>	Speed <i>rpm</i>	Max electrical supply		Input power <i>W</i>	Sound level (*) <i>db(A)</i>	Weight <i>kg</i>	Curve	Dimensions (mm)					
			<i>A</i>	<i>400V</i>					$\varnothing A$	$\varnothing B$	$\varnothing C$	<i>D</i>	$\varnothing E$	Number of holes
HEPT-31-2T/H	4000	2640	-	0.89	495	74	7.4	1	385	355	308	200	10	8
HEPT-31-2M/H	4000	2640	2.30	-	515	74	7.4							
HEPT-31-4T/H	2400	1410	-	0.40	115	55	6.2	2	385	355	308	200	10	8
HEPT-31-4M/H	2400	1410	0.75	-	140	55	6.2							

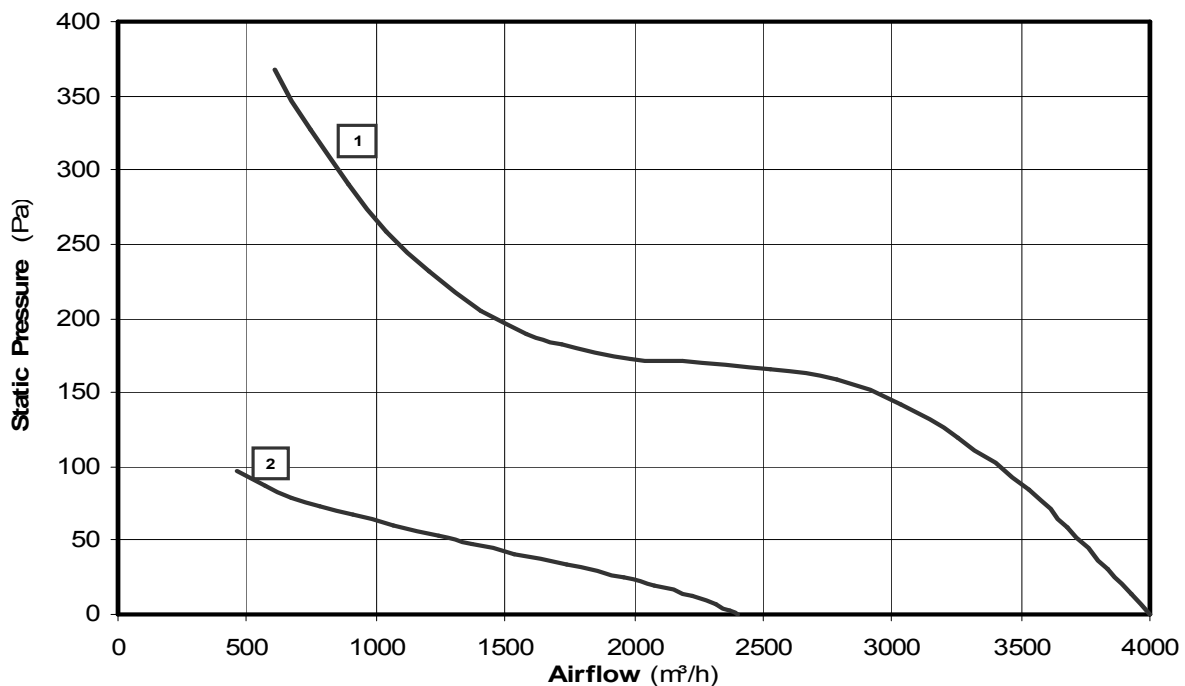
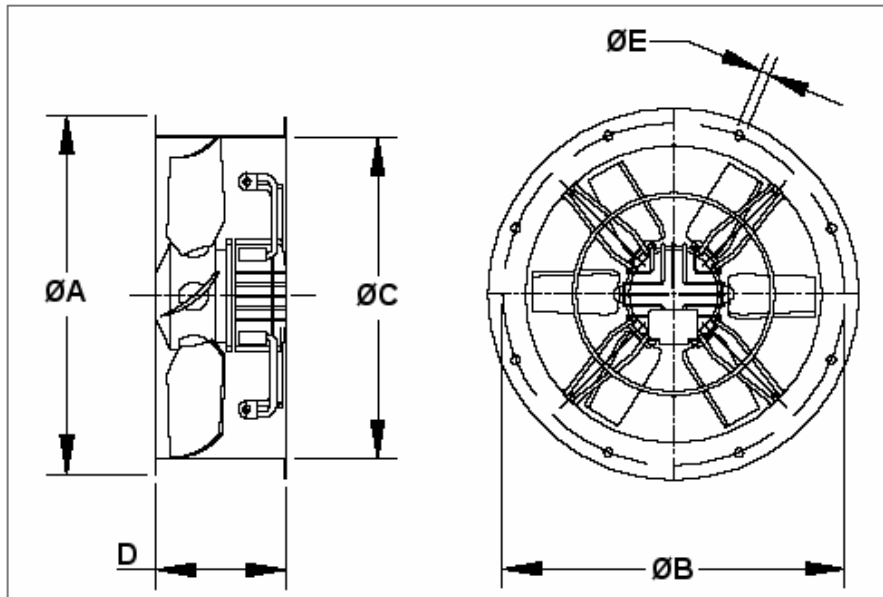

Axial Fans Cased HEPT Installation Guidance

It is intended that this range of products should be installed by a fully qualified and competent person, it should not be regarded as a DIY product.

ATTENTION: The fan consists of fast rotating parts, and is a dangerous machine! Protective guards are available but it is the sole responsibility of the installer to ensure that the fan can not be operated in an unsafe or dangerous manner.

Packaging and Delivery

The fan must be inspected for transit damage before any attempt to install it is made. The fan will have left our premises in perfect condition, protected in a cardboard box. If there are any doubts as to the condition of the fan it **MUST** be noted on the carriers delivery paperwork.

Handling

All the units must be handled with care at all stages, if the blades are distorted during installation it will cause unacceptable vibration and shorten the life of the motor bearings. Under no circumstances must the unit be carried by the fan blades and ensure that any lift slings do not touch the impeller. Do not allow the case to twist.

Installation-mechanical

The fans should be fitted internally and supported independently of any ductwork. The fan must not be directly exposed to water spray or steam or heat (in excess of 45°C). The weight of the fan is stated on the web site and the installer must ensure that the structure is strong enough to accept the extra loading, it is the responsibility of the installer that this has not weakened the integrity of the building/structure.

There are mounting holes punched around the circumference of the mounting flanges, the correct bolts or screws must be used to ensure a safe and stable siting of the fan.

A correctly sized Gravity Louvre Shutter should be fitted on the outside wall to stop draughts through the ducting and into the building when the fan is non operational.

Installation-electrical

Note: All our fans are fitted with a thermal protector, embedded in the windings of the motor. If the protector is correctly connected it is impossible to burn out the motor. Failure to utilise this safety feature will invalidate any warranty claim.

The rating label gives details of the motor power and the correct size and rating cable must be selected. An isolator should be fitted as part of the motor protection circuitry, a fuse is NOT an adequate method of protection.

It is important that the electrical demand does not exceed the data on the motor rating label; particularly the current drawn (A). The fan should be allowed to run for a minimum of 1 hour to allow the current (A) to settle. After 1 hour the fan should be switched off and the installation checked to ensure that nothing has worked loose.

It is recommended that the motor is NOT operated in reverse because the blades have been optimised for the maximum performance in a single direction of rotation.

Warranty

The cased axial fans are guaranteed for 12 months from the date of delivery and covers faulty materials and workmanship. The earlier warnings about correct installation are important and any failures that might be attributed to poor installation practices will void the warranty.